



Instruction Manual for the MicroPower eLogger Multi-Expander Document Version 1.4

Thank you for your purchase! This instruction manual will guide you through the installation and operation of your Multi-Expander Sensor (the Expander). **Please read the entire manual carefully before proceeding.** If, after you read the manual, you have further questions or problems, see the Support page on <http://www.eagletreesystems.com> for additional information, or email us at support@eagletreesystems.com.

IMPORTANT: It is unlikely that the installation of the Expander will affect your model's radio range or control. But, as always after making an electronics change to your model, it is very important that you range and function test your model once the Expander is installed to ensure that there is no impact on your system. Make sure that your "antenna down" operating range is within the manufacturer's specifications. See your Radio owner's manual for the correct procedure for your equipment. **DO NOT OPERATE IF YOUR MODEL DOESN'T PASS THE ANTENNA DOWN RANGE CHECK.**

Packing List

Your package should include the following: The Multi-Expander Sensor, one universal Y-Cable, and a printed version of this manual. Please check our support web page for the electronic version of this manual which may be updated if changes were made after printing.

What the Expander Does

The Expander connects to your MicroPower eLogger to provide 3 features:

- Measurement of RPM via pulses from either one or two of the wires leading from your Electronic Speed Controller (ESC) to your motor. In most cases, only one wire needs to be connected. The Expander works with all known brushless motors.
- Measurement of Throttle (or other) Servo position.
- Measurement of two temperatures simultaneously, in addition to RPM (normally only one temperature can be measured when RPM is being measured).

Supported Products

The Expander works with all versions of the MicroPower eLogger product.

Steps to Follow

Installation and use of your Expander should be quite easy and enjoyable if you follow these few steps:

1. Read through the manual to understand the warnings, determine the installation and setup sequence, etc.
2. Upgrade the Windows Application and Firmware for your MicroPower as described in the "Windows Application and Firmware Update" section below.
3. Complete the installation as described below.

Windows Application and Firmware Update

To use the Expander, you must update to **Eagle Tree Windows Application version 5.50** or higher. To update, download the latest application from the support page of our website. After downloading and installing the Application, the firmware of your MicroPower eLogger will need to be updated.

Firmware version 4.91 or greater is required for the Expander to work correctly. To upgrade your firmware, choose "Tools, Firmware Control!" and click the Update button.

Connecting the Expander to the MicroPower

The Expander plugs into the both the RPM and Temperature ports of the MicroPower, as shown in Figure 1.

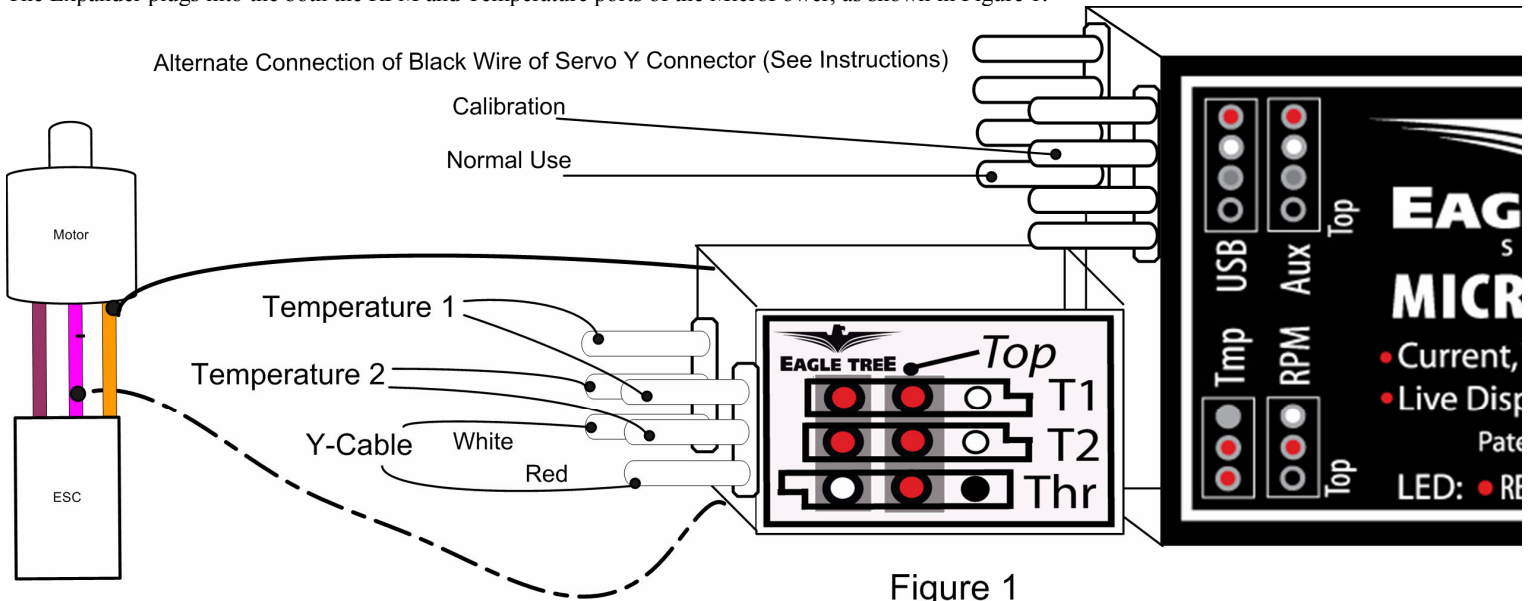

Figure 1

Connecting the RPM Wire(s) to your Power System

WARNING: The wires of the Expander are designed to carry only the tiny currents required for the Expander to measure RPM. The wires must never be connected in a way where large current could flow through them, or in a way where they could become damaged and short with other conductors.

WARNING: High Voltages can cause electric shock. Be extremely careful when working with high voltage packs! Work with high voltages at your own risk!

IMPORTANT: Only connect your battery pack to the MicroPower AFTER all other connections are made to the MicroPower and Multi-Expander.

There are two unconnected red wires extending from the Expander. Normally, only the wire nearest the Eagle Tree logo on the label needs to be electrically connected to any 1 of the 3 wires leading from your ESC to your motor. The end of this wire can be soldered, clipped or otherwise electrically connected to one of the motor wires. If you use “bullet” type plugs between your motor and ESC, it is very easy to connect the RPM sensor wire, by just stripping off a short piece of the insulation, and connecting the bullet plug with the stripped RPM wire inside it.

For convenience, if you plan on frequently moving the Sensor between motors, a small plug could be attached to one of the motor leads and the mating plug attached to the “To Motor 1” wire. Or, for more portability, if it can be done safely, a short straight pin could be connected to the Sensor “To Motor 1” wire, and the pin could be used to pierce the insulation of one of your motor wires, thus forming an electrical connection.

In the unlikely event that the Sensor provides no RPM signal when only the Motor 1 wire is connected, it will be necessary to connect the “To Motor 2” wire to a second motor wire, as shown in Figure 3. In this configuration, two of the three motor wires will be connected to the Sensor.

Configuring and Calibrating the RPM Function of the Expander with the Windows Application

If you have not already done so, set up the Recorder software as described in your instruction manual.

To calibrate the RPM sensor, you need to know the number of “poles” your brushless motor has. This information is normally supplied by the motor manufacturer. For “outrunner” motors, the term “poles” refers to the number of magnets in the motor (NOT the number of stator teeth, “legs,” or “hammerheads.”) For example, if you have an outrunner with 10 teeth on the stator and 14 magnets in the flux ring, the motor has 14 poles. For “inrunner” motors with a central magnet, the term “poles” refers to the number of magnetic poles present on each magnet (always 2, so enter a “2” for poles).

If you are uncertain about the number of poles, or want to verify you calculated correctly, a hand-held tachometer can be used to compare the RPM value displayed real-time by your MicroPower, in a bench test (assuming it is safe for you to do this). Real-time display is available in Recorder USB Live Mode, on the MicroPower PowerPanel, or with the Seagull Wireless Dashboard. If the value displayed is incorrect, you can change the poles setting to adjust the displayed RPM value. For example, if your handheld tachometer reads 4000 RPM, and your Eagle Tree data shows the maximum RPM of 8000, you would need to double the number of poles to “2.”

Click on “Tools, Calibrate Motor RPM”, select the “Brushless Motor RPM Sensor” option, and enter the number of Poles and the gear ratio.

Logging RPM

To RPM, just click “Tools, Choose Parameters to Log in the Recorder” and check the “RPM” box.

Displaying RPM in the Windows Application

To display the RPM Gauge and/or Numeric Display, click “Tools, Choose Instruments to Display on the PC Screen” and check the “Motor RPM Gauge,” “Numeric Motor RPM” and/or “Propeller RPM/Head speed” boxes.

Graphing RPM

To RPM, click “Graph Data/2D Chart,” select either the Left Y Axis or Right Y Axis, and select “Motor RPM” and/or “Prop RPM/Head speed” for graphing.

Displaying RPM on the PowerPanel

Select “Tools, Configure PowerPanel Display”, and choose “Motor RPM” and/or “Prop RPM/Head speed” for PowerPanel display.

Connecting the Throttle Servo Y-Cable to your Throttle, and to the Expander

The Expander logs servo positions by measuring the pulses coming from your receiver to the throttle servo, via the included Y cable. The Y Cable has 3 connections. The “Futaba” male plug (at the “base of the Y”) connects to the Expander, vertically, as shown in Figure 1 and on the Sensor label. Only the white and red wires of the Y cable’s Futaba male connector connect to the Expander. The black wire of the Futaba connector is unconnected. The other two plugs of the Y cable connect to your receiver’s throttle channel, and to your throttle servo. See Figure 2 for connections of the Y cable to your Receiver and Servo.

IMPORTANT: Make sure you connect the battery pack to the MicroPower only AFTER connecting the throttle Y cable to the MicroPower (and all other connections). This is to prevent the negative side

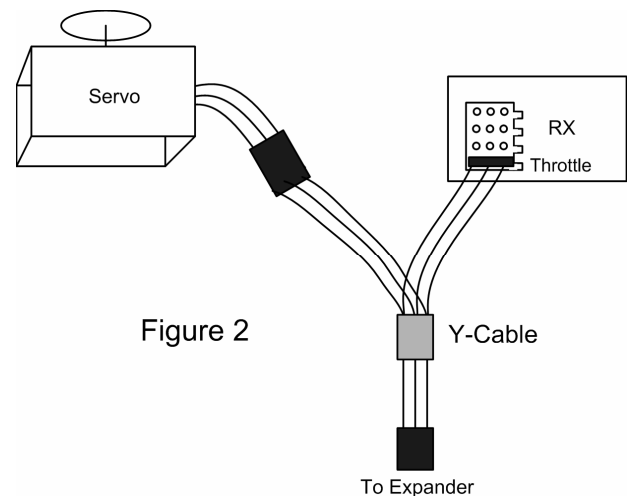

Figure 2

of your battery pack from being connected only to the MicroPower, but not the ESC, when the positive side of the pack is connected to both the ESC and the MicroPower, causing the MicroPower to sink high voltage through the throttle monitor connection of the multi-expander, and damaging the MicroPower and other equipment.

IMPORTANT: For the throttle logging to work correctly, the ground (black) wire of the throttle servo must be connected electrically to the ground (black) wire of the battery pack. Some BECs or ESCs isolate battery ground from BEC ground. Or, sometimes a separate battery pack is used to power the receiver. In these cases, it is not possible to log throttle movements, unless a connection is made between the two grounds. One way to do this is to remove the black pin of the Y-Cable (the end that connects to the Expander), and connect that pin to one of the ground pins of the MicroPower. See Figure 1 for locations of the two alternate pin connections. Normally the end pin on the bottom row (USB Connection) is used, but during calibration, the 2nd pin of the upper row must be used, since the USB plug has to be connected during calibration. This connection will create a closed circuit between your receiver's ground and the battery pack's ground. **NOTE THAT THIS BYPASSES ANY ISOLATION BUILT INTO THE ESC BETWEEN THE BATTERY GROUND AND THE BEC GROUND.** We are aware of no issues with connecting a wire between battery ground and receiver ground in these cases, but proceed with caution (at your own risk) as there is the unlikely possibility that your hardware may be damaged by such a connection, and make sure you do an antenna down range check after making this change.

Configuring and Calibrating the Throttle Function of the Expander with the Windows Application

If you have not already done so, set up the Recorder software as described in your instruction manual.

IMPORTANT: for throttle monitoring to calibrate and work correctly, you must choose the “Brushless RPM Sensor” option. To do this, click on “Tools, Calibrate Motor RPM”, select the “Brushless Motor RPM Sensor” option, and enter the number of Poles and the gear ratio, as described below. After selecting the “Brushless RPM Sensor” option, please remove the USB cable from the eLogger, and then reconnect it. This allows the eLogger to “reboot” and correctly detect the Multi-Expander.

NOTE: If you do not plan to use the brushless RPM sensor feature of the Multi-Expander, you can just enter any value for the number of poles and gear ratio. You do not need to connect the brushless RPM sensor wires to your motor to use the throttle monitor function, as long as the Brushless RPM Sensor option is selected in the software.

Calibrating Throttle Movement

It is not absolutely necessary to calibrate the throttle function. The advantages of calibration are that the throttle gauge and graphs will range from zero (closed throttle) to approximately 210 (maximum throttle), as you move your throttle between its extremes. If you do not calibrate, the throttle gauge and graphs will still show throttle movement, but the graph could be inverted if you have the throttle servo reversed, and will not go from zero to 210.

To calibrate the throttle with your model, first connect the Expander to the MicroPower, connect the Expander to your Receiver's Throttle output via the Y cable, and connect the MicroPower to your PC via the USB cable. Then, click “Tools, Calibrate Throttle.” The Calibrate Throttle Wizard will then explain the calibration procedure.

Logging Throttle Movement

To log throttle movement, just click “Tools, Choose Parameters to Log in the Recorder” and check the “Throttle Movement” box.

Displaying Throttle Movement in the Windows Application

To display the Throttle Movement Gauge, click “Tools, Choose Instruments to Display on the PC Screen” and check the “Throttle Gauge” box.

Graphing Throttle Movement

To graph throttle movement, click “Graph Data/2D Chart,” select either the Left Y Axis or Right Y Axis, and select “Throttle” for graphing.

Connecting Temperature Sensors to the Expander

One or two temperature sensors can connect to the Expander. These connect vertically, with only two pins, as shown in Figure 1. Note that Display, Logging and Graphing of temperature is described in the MicroPower instruction manual. The only difference is that two temperature sensors can be used simultaneously, even when logging RPM.

Troubleshooting

Below is a list of problems that may be encountered, and steps to remedy them. If your particular issue is not addressed by the below, see the Support page on <http://eagletreesystems.com> or email support@eagletreesystems.com. Include a full description of your problem, your machine configuration, brands/models of receivers, transmitters and servos, Windows Application and Recorder firmware version if possible, and any other relevant details.

Issue: RPM is not working correctly

Solutions:

- In the Windows Application, make sure that the “Brushless Motor RPM Sensor” option is selected in “Tools, Calibrate Motor RPM” or “Tools, Calibrate Speed from RPM”, and make sure your number of poles and gear ratio are set correctly.
- For recording RPM, make sure that when you click “Tools, Choose Parameters to Log in the Recorder” in the Windows Application, you have checked the RPM box.
- If you get no RPM readings, and have connected only one of the Brushless Sensor wires to 1 of the 3 wires leading from your ESC to your Motor, try connecting both of the unconnected sensor leads to 2 of the 3 wires leading from your ESC to your Motor, as shown in Figure 1.

Issue: Temperature is not reading correctly

Solutions:

- Ensure you have connected the Temperature Sensor(s) vertically to the Expander as shown in Figure 1.
- Make sure you are logging temperature in the MicroPower.
- See the Troubleshooting section on Temperature in the MicroPower instruction manual.

Issue: Throttle Movements are not correct, or the throttle cannot be calibrated.

Solutions:

- Ensure you have connected the Y cable as shown in Figure 1.
- Ensure you have chosen the “Brushless RPM Sensor” option as described in the Throttle Configuration section of the manual.
- Make sure you are logging throttle movements in the MicroPower.

Limited Warranty

Eagle Tree Systems, LLC, warrants the Multi-Expander to be free from defects in materials and workmanship for a period of one (1) year from the date of original purchase. This warranty is nontransferable. If your unit requires warranty service during this period, we will replace or repair it at our option. Shipping cost to us is your responsibility. To obtain warranty service, email support@eagletreesystems.com for further instructions.

This limited warranty does not cover:

- The Software. See the Software license agreement for more information on Software restrictions.
- Problems that result from:
 - External causes such as accident, abuse, misuse, or problems with electrical power
 - Servicing not authorized by us
 - Usage that is not in accordance with product instructions
 - Failure to follow the product instructions

THIS WARRANTY GIVES YOU SPECIFIC LEGAL RIGHTS, AND YOU MAY ALSO HAVE OTHER RIGHTS WHICH VARY FROM STATE TO STATE (OR JURISDICTION TO JURISDICTION). OUR RESPONSIBILITY FOR MALFUNCTIONS AND DEFECTS IN HARDWARE IS LIMITED TO REPAIR AND REPLACEMENT AS SET FORTH IN THIS WARRANTY STATEMENT. ALL EXPRESS AND IMPLIED WARRANTIES FOR THE PRODUCT, INCLUDING, BUT NOT LIMITED TO, ANY IMPLIED WARRANTIES AND CONDITIONS OF MERCHANTABILITY AND FITNESS FOR A PARTICULAR PURPOSE, ARE LIMITED IN TIME TO THE TERM OF THE LIMITED WARRANTY PERIOD AS DESCRIBED ABOVE. NO WARRANTIES, WHETHER EXPRESS OR IMPLIED, WILL APPLY AFTER THE LIMITED WARRANTY PERIOD HAS EXPIRED. SOME STATES DO NOT ALLOW LIMITATIONS ON HOW LONG AN IMPLIED WARRANTY LASTS, SO THIS LIMITATION MAY NOT APPLY TO YOU.

WE DO NOT ACCEPT LIABILITY BEYOND THE REMEDIES PROVIDED FOR IN THIS LIMITED WARRANTY OR FOR CONSEQUENTIAL OR INCIDENTAL DAMAGES, INCLUDING, WITHOUT LIMITATION, ANY LIABILITY FOR THIRD-PARTY CLAIMS AGAINST YOU FOR DAMAGES, FOR PRODUCTS NOT BEING AVAILABLE FOR USE, OR FOR LOST DATA OR LOST SOFTWARE. OUR LIABILITY WILL BE NO MORE THAN THE AMOUNT YOU PAID FOR THE PRODUCT THAT IS THE SUBJECT OF A CLAIM. THIS IS THE MAXIMUM AMOUNT FOR WHICH WE ARE RESPONSIBLE. SOME STATES DO NOT ALLOW THE EXCLUSION OR LIMITATION OF INCIDENTAL OR CONSEQUENTIAL DAMAGES, SO THE ABOVE LIMITATION OR EXCLUSION MAY NOT APPLY TO YOU.